



پوهنتون کاردان  
KARDAN UNIVERSITY

**MODERN PROGRAMMING LANGUAGE**  
**(Python/Java/Rust/Dart)**

# Introduction to Python



# Info:



- Instructor: Sayed Mortaza Kazemi
  - Office Phone: 0795474969
  - Email: [sayedmortaza11@gmail.com](mailto:sayedmortaza11@gmail.com) / [m.kazemi@kardan.edu.af](mailto:m.kazemi@kardan.edu.af)

# Grading

- Midterm: 25%
- Final: 50%
- Assignment & Projects: 15%
- Homework and practice: 10%
- **Bonus Marks (Will be adjusted in your overall marks)**

Full Attendance	10 Marks
1 day short	6 Marks
2 day short	4 Marks
3 day short	2 Marks



# Required to have knowledge

- Fundamentals of Programming
- Object Oriented Programming



# Focus of the Course

- This is a **PROJECT** based course.
- Object-Oriented Software Development
  - problem solving
  - program design, implementation, and testing
  - Python GUI Framework, graphical user interfaces
  - object-oriented concepts
    - Classes and objects
    - encapsulation
    - inheritance
    - polymorphism



# Learning Python, 5th Edition

by **Mark Lutz**

Released June 2013

Publisher(s): O'Reilly Media, Inc.

ISBN: 9781449355722





# Learning Outcomes

- Should Understand What is Python?
- What is History of Python?
- What are Python features?
- Which Python 2 or 3 should we learn and Use?
- How to run python program?





# What is Python Programming language

- What is Python programming Language?
- Python is a High-level programming language for general-purpose programming, created by Guido van Rossum and first released in 1991.





# Why python?

- Developer Productivity (1/3—1/5 of others), Runs Immediately
- Support libraries
- Component integration
- Data Science, Gaming, Robots etc..
- It's Mixable





# Companies that use python

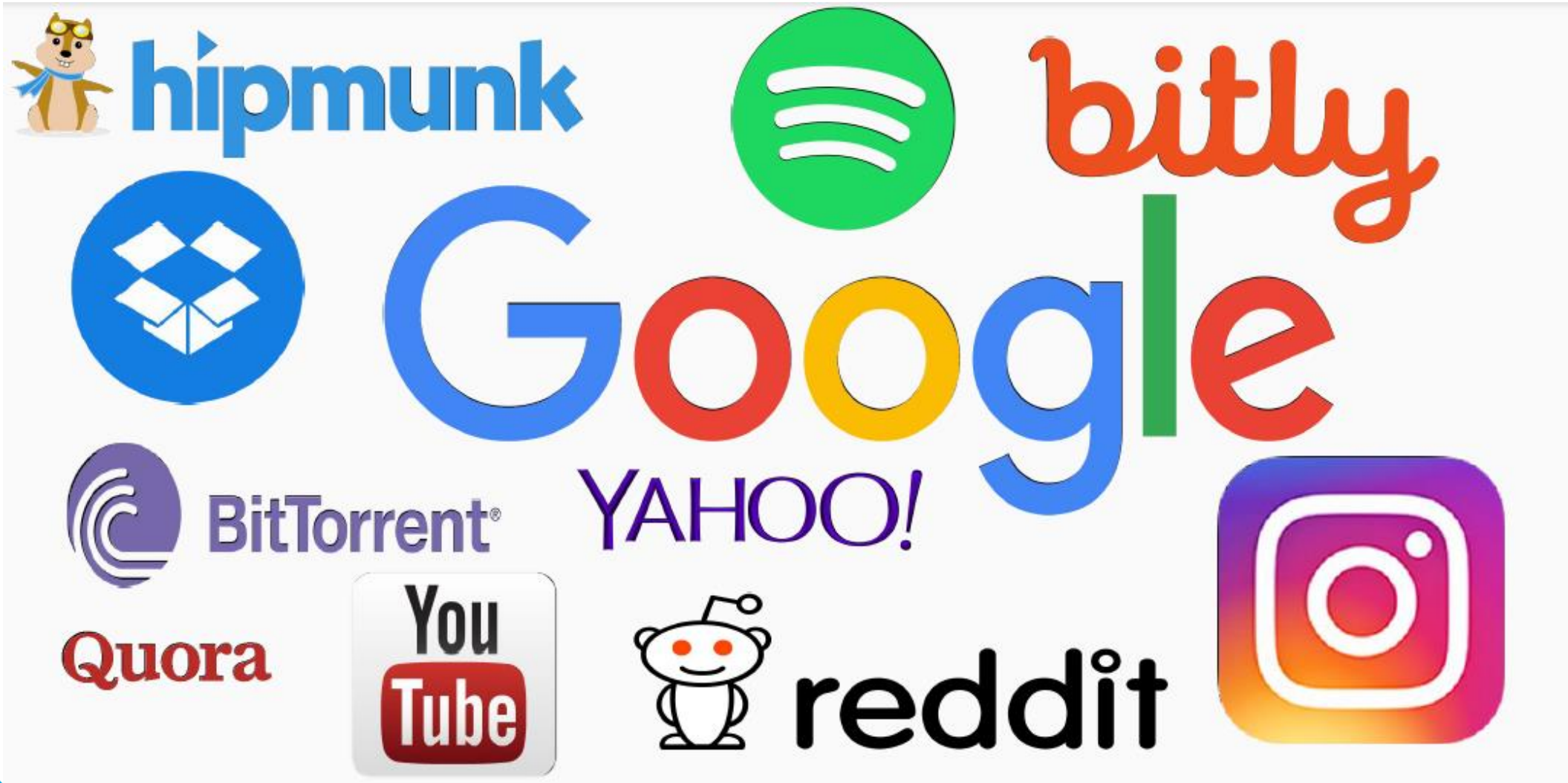



Contd..

*Pinterest*

The Washington Post



 **Bitbucket**

*Eventbrite*<sup>TM</sup>





# History of Python

- Started implementation at year 1989 by Guido van Rossum , Netherlands
- Python 2.0 was released on October 16, 2000
- Latest version for Python 2.7 is July,3, 2010
- Python 3.0, a major, backwards-incompatible release, was released on December 3, 2008
- Latest version for Python **3.14.3** (03 Feb 2026)





**PYTHON 2**

VS.

**PYTHON 3**

WHICH SHOULD I LEARN?

LEARNTOCODEWITH.ME



# Python 2 vs Python 3

- Companies have been moving from Python 2 to 3
- Although Python 2.7 is still widely used, Python 3 adoption is growing quickly.
- Python 2.7 will “retire” and no longer be maintained ...2020





Contd..

## PYTHON 2

## PYTHON 3

← **Legacy**

It is still entrenched in the software at certain companies

 **Library**

Many older libraries built for Python 2 are not forwards-compatible



**Future** →

It will take over Python 2 by 2020

**Library** 

Many of today's developers are creating libraries strictly for use with Python 3





# Python Compared to Java

Data Flair Python vs Java

Dimensions	Python	Java
Verbosity	Concise	Verbose
Performance	Interpreted, slower	Faster
Learning Curve	Easier than Java	Easy
Typing discipline	Dynamically-typed (duck-typing)	Statically-typed
Best for	Data Science, AI, Machine Learning	Embedded and cross-platform applications





## Development Time Comparison

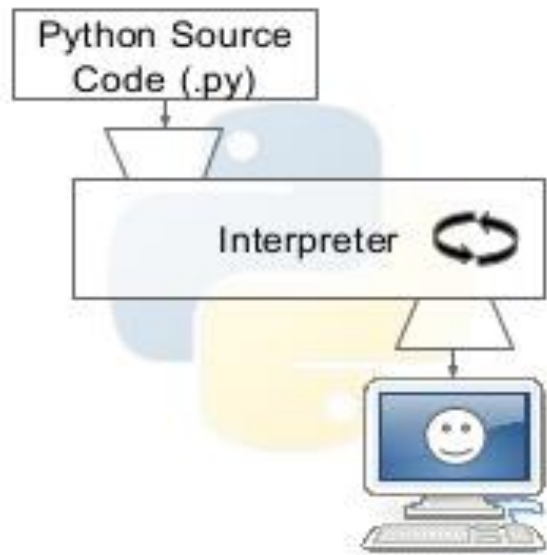

Interpreted Language

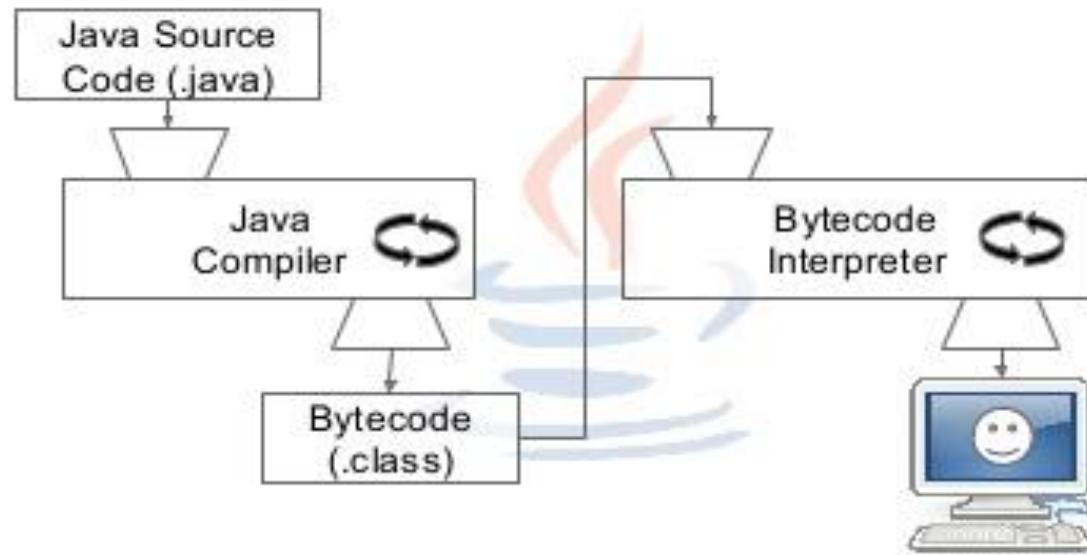

Compiled Language





# Python Compared to Other

## Language comparison

	Python	Ruby	JS/ Node.js	C/C++	Java	Go
<b>semicolons</b>	N	N	Y	Y	Y	N
<b>curly braces</b>	N	N*	Y	Y	Y	Y
<b>static types</b>	N	N	N	Y	Y	Y
<b>easy-to-use concurrency</b>	N	N	Y	N	N	Y
<b>multi-core concurrency</b>	N	N	N	Y	Y	Y
<b>compiled</b>	N	N	N	Y	Y	Y
<b>OO: classes, inheritance</b>	Y	Y	Y	Y	Y	N*



Easy

01

Extensible

07

Expressive

02

Embeddable

08

Free and  
Open Source

03

Interpreted

09

High-Level

04

Large Standard  
Library

10

Portable

05

GUI  
Programming

11

Object  
Oriented

06

Dynamically  
Typed

12

Features of



# Python



## a. Easy to Code

- Compared to other popular languages like Java and C++, it is easier to code in Python. Anyone can learn Python syntax in just a few hours. Mastering Python requires learning about all its advanced concepts and packages and modules, and it is programmer-friendly.

## b. Easy to Read

- Being a high-level language, Python code is quite like English. Looking at it, you can tell what the code is supposed to do. Also, since it is dynamically-typed, it mandates indentation. This aids readability.





## Expressive

- Python provides us with a countless number of constructs that help us focus on the solution rather than on the syntax. This is one of the outstanding python features that tell you why you should learn Python.
- Suppose we have two languages A and B, and all programs that can be made in A can be made in B using local transformations. However, there are some programs that can be made in B, but not in A, using local transformations. Then, B is said to be more expressive than A.





## High-Level, Free and Open-Source

- Python is freely available. You can download it from the Python Website. It is open-source. This means that its source code is available to the public. You can download it, change it, use it, and distribute it. This is called FLOSS(Free/Libre and Open Source Software).
- It is a high-level language. This means that as programmers, we don't need to remember the system architecture. Nor do we need to manage the memory. This makes it more programmer-friendly and is one of the key python features.





## Portable

- Assume you've written a Python code for your Windows machine. Now, if you want to run it on a Mac, you don't need to make changes to it for the same. In other words, you can take one code and run it on any machine, there is no need to write different code for different machines. This makes Python a portable language. However, you must avoid any system-dependent features in this case.





## Interpreted

- Languages like C++ or Java, you must first compile it, and then run it. But in Python, there is no need to compile it. Internally, its source code is converted into an immediate form called bytecode. So, all you need to do is to run your Python code without worrying about linking to libraries, and a few other things.
- By interpreted, we mean the source code is executed line by line, and not all at once. Because of this, it is easier to debug your code. Also, interpreting makes it just slightly slower than Java, but that does not matter compared to the benefits it has to offer.





## Object-Oriented, Extensible

- A programming language that can model the real world is said to be object-oriented. It focuses on objects and combines data and functions. Contrarily, a procedure-oriented language revolves around functions, which are code that can be reused. Python supports both procedure-oriented and object-oriented programming which is one of the key python features. It also supports multiple inheritances, unlike Java. A class is a blueprint for such an object. It is an abstract data type and holds no values.
- If needed, you can write some of your Python code in other languages like C++. This makes Python an extensible language, meaning that it can be extended to other languages.





## Embeddable, Large Standard Library

- It is possible to put our Python code in a source code in a different language like C++. This allows us to integrate scripting capabilities into our program of the other language.
- Python downloads with a large library that you can use so you don't have to write your own code for every single thing. There are libraries for regular expressions, documentation-generation, unit-testing, web browsers, threading, databases, CGI, email, image manipulation, and a lot of other functionality.





# GUI Programming, Dynamically Typed

- A software is not user-friendly until its GUI is made. A user can easily interact with the software with a GUI. Python offers various libraries for making Graphical user interface for your applications. For this, you can use Tkinter, PyQt, wxPython or JPython. These toolkits allow you for easy and fast development of GUI.
- Python is dynamically-typed. This means that the type for a value is decided at runtime, not in advance. This is why we don't need to specify the type of data while declaring it.





# How Python Programs Run

- There is a software package called an interpreter. An interpreter is a kind of program that executes other programs.
- It is a layer of software logic between your code and the computer Hardware





# Contd..

- For ex:
- `print (' My First Python Program')`
- 1. The interpreter changes it to bytecode...
- 2. The bytecode is executed by Python Virtual Machine (PVM)

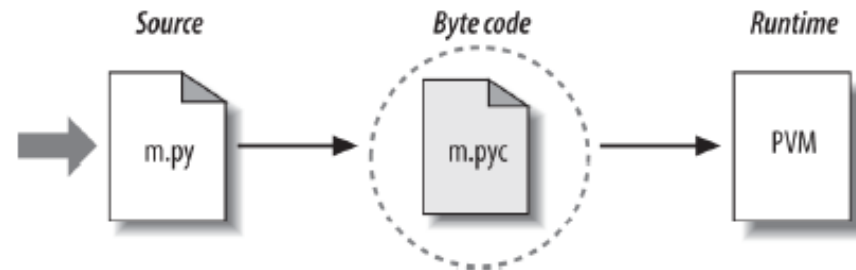



# Variable Assignment

- We use the **assignment operator (=)** to assign values to a variable. Any type of value can be assigned to any valid variable.

```
a_name = "John Doe"  
a_age = 12  
a_gender = "Male"  
a_ave = 84.92
```

```
a, b, c = 5, 3.2, "Hello"
```

```
a = 10  
b = 12  
  
sum = a + b  
print (sum)
```





# How to write a Program in Python

## Run your First Python Program





# How to run a Python Program?

- Install Anaconda Software, Thonney or Python IDLE
- **Steps:**
  - Visit [Anaconda.com/downloads](https://anaconda.com/downloads)
  - Select Windows
  - Download the **.exe** installer
  - Open and run the **.exe** installer
  - Open the **Anaconda Navigator**
  - Select **Jupyter Notebook**
  - Run the **python code**





# Jupyter Notebook

Anaconda Navigator

File Help

ANACONDA NAVIGATOR

Sign in to Anaconda Cloud

Home

Environments

Learning

Community

Documentation

Developer Blog

Applications on  Channels Refresh

 JupyterLab 0.35.4 An extensible environment for interactive and reproducible computing, based on the Jupyter Notebook and Architecture. Launch	 Notebook 5.7.8 Web-based, interactive computing notebook environment. Edit and run human-readable docs while describing the code analysis. Launch	 Spyder 3.3.3 Scientific PYTHON Development Environment. Powerful Python IDE with advanced editing, interactive testing, debugging and introspection features Launch	 Glueviz 0.13.3 Multidimensional data visualization across files. Explore relationships within and among related datasets. Install
 Orange 3 3.19.0 Component based data mining framework	 RStudio 1.1.456 A set of integrated tools designed to help	 VS Code Streamlined code editor with support for	

File Edit View Insert Cell Kernel Widgets Help

Trusted | Python 3 

- New Notebook ▶
- Open...
- Make a Copy...
- Save as...
- Rename...
- Save and Checkpoint
- Revert to Checkpoint ▶
- Print Preview
- Download as ▶
- Trusted Notebook
- Close and Halt

Python 3

  Code ▼ 

```
('this is my first python code')
```

```
is my first python code
```













```
In [ ]:
```



# Writing the code

 **jupyter** Untitled5 Last Checkpoint: a few seconds ago (unsaved changes)

File Edit View Insert Cell Kernel Widgets Help

        Run    Code 

```
In [ ]: a=10
        b=20
        x=a+b

        print (x)
```





## Exercises

- Accept two numbers from the user and calculate multiplication
- Accept any three string from one input() call?





# Presentation Assignment

- What is MVC?
- Which Frameworks of Python Support MVC, explain one of them with example?
- What are different types of programming techniques for solving a Problem?
  - e.g. Dynamic Programming, Greedy Programming, Linear Programming ..etc







- To install Anaconda, follow these steps:
- Visit the Anaconda website: Go to the Anaconda website at <https://www.anaconda.com/products/individual> and navigate to the "Anaconda Individual Edition" download page.
- Choose the appropriate version: Make sure to select the correct version of Anaconda based on your operating system (Windows, macOS, or Linux) and architecture (32-bit or 64-bit).
- Download the installer: Click on the download button for the desired version to start the download. The file size may be large, so it may take some time depending on your internet connection.





- Run the installer: Once the download is complete, locate the downloaded installer file and run it. On Windows, it will be an executable file with a .exe extension. On macOS, it will be a .pkg file.
- Follow the installation instructions: The installer will guide you through the installation process. Follow the on-screen instructions and make any desired configuration choices.
- Choose the installation location: You can choose the default installation location or specify a different directory.
- Select whether to add Anaconda to your system PATH: It is recommended to select the option to add Anaconda to your system PATH, as it allows you to use Anaconda from the command line.
- Choose whether to install Anaconda for all users or just your user account: Select the appropriate option based on your needs.
- Complete the installation: Once you have made your selections, proceed with the installation. It may take a few minutes for the installation process to complete.





- Verify the installation: After the installation is finished, you can verify that Anaconda has been installed successfully by opening a new terminal or command prompt window and running the following command:
- shell
- Copy
- `conda --version`
- If Anaconda is installed correctly, it will display the version number of your Anaconda distribution.
- Congratulations! You have successfully installed Anaconda on your system. You can now start using Anaconda and its associated tools, such as conda and Jupyter Notebook, for your data science and Python development projects.





- Do we need python also if we install anaconda?
- No, you do not need to separately install Python if you install Anaconda. Anaconda comes bundled with its own distribution of Python, along with a wide range of additional packages and tools specifically curated for data science and scientific computing.
- When you install Anaconda, it installs a complete Python environment, including the Python interpreter and the necessary libraries and packages used in data analysis, machine learning, and other scientific computing tasks. Anaconda provides its own package manager called conda, which can be used to install, manage, and update packages.
- Anaconda also includes other useful tools such as Jupyter Notebook, JupyterLab, Spyder, and more, which are commonly used in data science workflows.
- By installing Anaconda, you get a self-contained Python environment that is ready to use for data science and scientific computing without the need for a separate Python installation.





پوهنتون كاردان  
KARDAN UNIVERSITY

Thank You